

Industrial

EU Stage V-capable*
55 kW / 74 hp

Perkins®
SYNCRO

2.8 litre

The Perkins® Syncro engines offer a compact power solution for off-highway applications in construction, agriculture and industrial.

For our customers these compact, 4 cylinder engines provide excellent performance in power, peak and low speed torque, fuel consumption and transient response.

Reliability and easy service access are integral to the design of the engines. It is available with a range of installation options to enable OEMs to minimise the size of the engine bay of their machines.

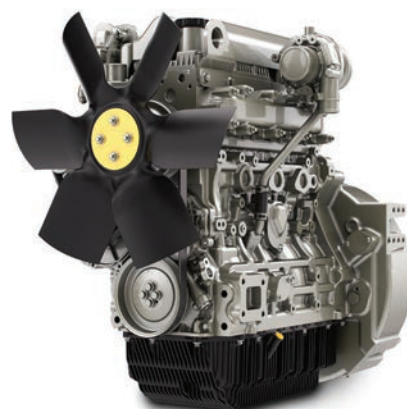

Emissions

EU Stage V-capable* emissions standards

Specification	904J-E28TA	
Number of cylinders	4 vertical in-line	
Bore and stroke	90 x 110 mm	3.5 x 4.3 in
Displacement	2.8 litres	171 cubic in
Aspiration	Turbocharged aftercooled	
Cycle	4 stroke	
Combustion system	Direct injection	
Compression ratio	17:1	
Rotation	Anti-clockwise, viewed on flywheel	
Total lubricating capacity	7.5 litres	1.9 US gal
Cooling system	Liquid	
Total coolant capacity	4 litres	1 US gal

*as proposed Stage V emissions standards

www.perkins.com

Photographs are for illustrative purposes only and may not reflect final specification.
All information in this document is substantially correct at time of printing and may be altered subsequently.
Final weight and dimensions will depend on completed specification.

Publication No. PN3129B/04/16 Produced in England ©2016 Perkins Engines Company Limited

 **Perkins®**

THE HEART OF EVERY GREAT MACHINE

Industrial

EU Stage V-capable*
55 kW / 74 hp

Perkins®
SYNCRO

2.8 litre

Features and benefits

Dependable power

- The engine has been designed using the latest predictive engineering methods, combined with an extensive field validation program to ensure reliable power in the toughest off-highway conditions
- Quality, reliability and consistency are assured. Our facilities worldwide employ the same efficient processes, the same tested and validated components, and the same stringent quality controls wherever your engines are manufactured.

Lifetime of low cost

- Fuel consumption is optimised to match the operating cycles of a wide range of off-highway applications. No additional fluids or additives are required which lowers operating costs and operator training
- Hydraulic tappets, multi-vee belts and 500 hour service intervals enable low cost maintenance
- **Warranties and Perkins Platinum Protection**
We provide one-year warranties for constant speed engines and two-year warranties for variable speed models, as standard. These are supported by Perkins Platinum Protection that can be bought additionally
Discover more: www.perkins.com 'Parts and Service'

Industry leading flexibility

- A modular engine concept allows OEMs to design one engine installation for different regions. This reduces cost and development time for cooling pack, mounting, hydraulic and control interfaces

Local support, global coverage

- Perkins recognise that the customer relationship is important to machine manufacturers and we can offer a range of flexible solutions to help provide appropriate support, either to the OEM's network or directly to the machine customer
- Perkins information systems enable our distributors to quickly diagnose engine faults and identify the right parts. The Perkins logistics operation is able to dispatch more than 45,000 different parts from stock, reaching the customer within 24 hours
- To find your local distributor: www.perkins.com 'Our Network'

*as proposed Stage V emissions standards

www.perkins.com

Photographs are for illustrative purposes only and may not reflect final specification.
All information in this document is substantially correct at time of printing and may be altered subsequently.
Final weight and dimensions will depend on completed specification.

Publication No. PN3129B/04/16 Produced in England ©2016 Perkins Engines Company Limited

 **Perkins®**

THE HEART OF EVERY GREAT MACHINE

Industrial

EU Stage V-capable*
55 kW / 74 hp

Perkins®
SYNCRO

2.8 litre

Technical information

Air inlet

- Standard air cleaners. No mass air flow sensor required

Controls and electrics

- 12 or 24V systems
- Data interface via CANbus J1939
- Full electronic control
- High power alternator and starter motor options
- Glow plugs for best cold starting with minimum battery impact
- Sensors and robust wiring harness included

Flywheels and flywheel housing

- SAE3 or SAE4 flywheel housing
- Wide choice of interfaces for common transmissions and hydraulic pumps

Fuel system

- Electronic high pressure common rail
- Fuel filter - pre-connected, chassis mounted
- Water sensor included - early warning for operator

Lubrication system

- Oil filters. Mounting options available on either side of the engine
- Dipsticks. Choice of position and length
- Oil fillers. Multiple locations on engine to allow for choice of service access
- High incline sump. 35° continuous in all directions. Suitable for machines that are used on steep slopes

Power take-off

- SAE-A and SAE-B interfaces available

Standard emissions control

- Diesel Oxidation Catalyst (DOC), Diesel Particulate Filter (DPF)
- Aftertreatment mounted on engine as standard

General

- Cold-start capable with standard equipment to -20°C
- Supplied painted or lacquered

*as proposed Stage V emissions standards

www.perkins.com

Photographs are for illustrative purposes only and may not reflect final specification.
All information in this document is substantially correct at time of printing and may be altered subsequently.
Final weight and dimensions will depend on completed specification.

Publication No. PN3129B/04/16 Produced in England ©2016 Perkins Engines Company Limited

 **Perkins®**

THE HEART OF EVERY GREAT MACHINE

Industrial

EU Stage V-capable*
55 kW / 74 hp

Perkins®
SYNCRO

2.8 litre

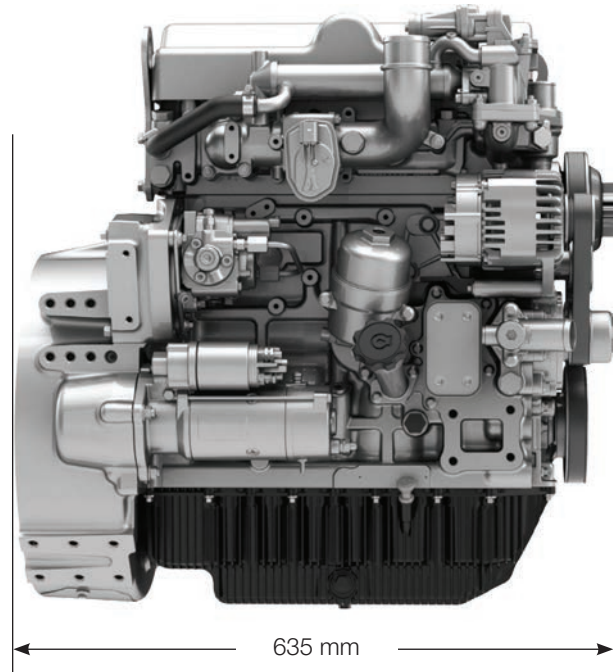
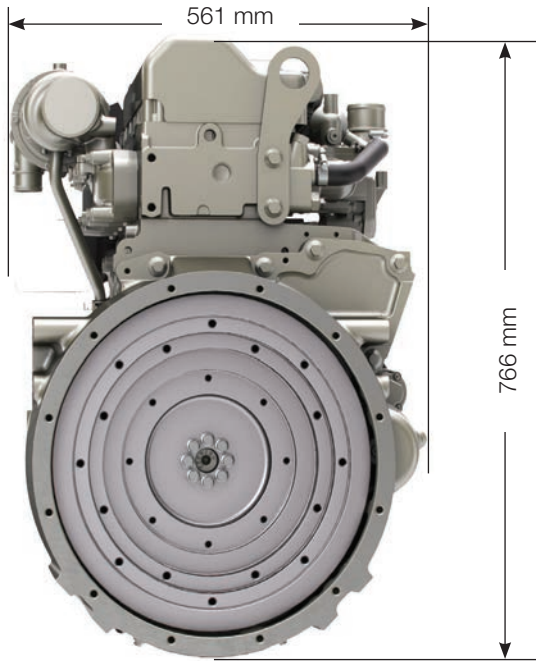

Engine package weights and dimensions

Length	635 mm	25.0 in
Width	561 mm	22.1 in
Height	766 mm	30.2 in
Weight (dry)	245 kg	540 lb

*as proposed Stage V emissions standards

www.perkins.com

Photographs are for illustrative purposes only and may not reflect final specification.
All information in this document is substantially correct at time of printing and may be altered subsequently.
Final weight and dimensions will depend on completed specification.

Publication No. PN3129B/04/16 Produced in England ©2016 Perkins Engines Company Limited

 **Perkins®**

THE HEART OF EVERY GREAT MACHINE

Industrial

EU Stage V-capable*
55 kW / 74 hp

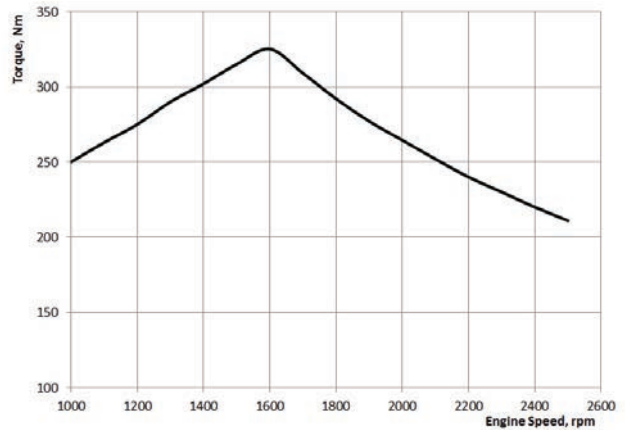
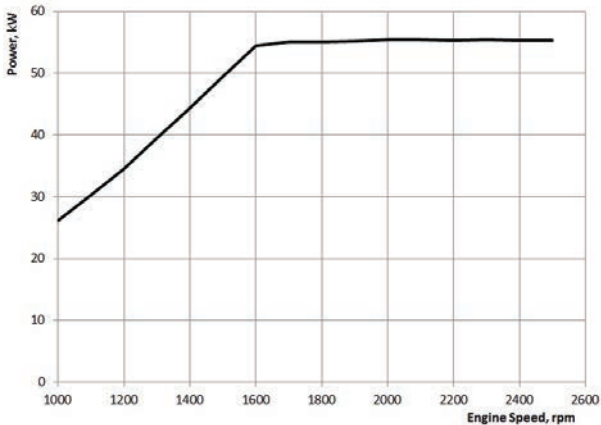

Speed rpm	Power kW	Power hp	Speed rpm	Torque Nm	Torque lbf-ft	Rating type
2500	55	74	1600	325	250	C

Rating definitions and conditions

IND-C (Intermittent) Is the horsepower and speed capability of the engine where maximum power and/or speed are cyclic (time at full load not to exceed 50%).

Rating Conditions for Diesel Engines – up to 7.1 litres

All rating conditions are based on ISO/TR14396, inlet air standard conditions with a total barometric pressure of 100 kPa (29.5 in. Hg), with a vapour pressure of 1 kPa (0.295 in. Hg) and 25°C (77°F). Performance is measured using fuel to specification EPA 40 CFR Part 1065 and EU Directive 97/68/EC with a density of 0.845-0.850 kg/L @ 15°C (59°F) and fuel inlet temperature 40°C (104°F).

*as proposed Stage V emissions standards